

2KINGEL



2 Kings

Youth Bible Study

by Pat Kampenga

Sample
Lesson

Joy of Living 2 Kings Youth Bible Study

Copyright 2007 • **Joy of Living Bible Studies** • Ventura, CA
(800) 999-2703 • (805) 650-0838 • Fax: (805) 650-6730 • E-mail: info@joyofliving.org

2 KINGS — WEEK 2

DISCUSSION LESSON 1

15 - 20 minutes Free time — games, fellowship

15 - 20 minutes Snack and group recreation: CHAIN TAG

Two players are chosen to be “IT.” They join hands and with their free hands try to tag the other players. The first player tagged joins hands between the two “IT.” The remaining players, when tagged, join the tag line between the original two “IT.” Only end players (IT) may tag. It is permissible for a player to break through or go under the joined hands of the line. When the chain has been broken, it must unite again before tagging resumes. The game ends when the last player is caught or when a time limit has been reached. The last two players tagged become “IT.” Set boundary lines to restrict play to a small area.

15 - 20 minutes Discuss LESSON 1

to end of class CRAFT: BROWN BAG KITE

MATERIALS FOR KITE:

scissors
ruler
masking/Scotch tape
hole punch

grocery or lunch bag
pencil
markers (optional)
cotton string

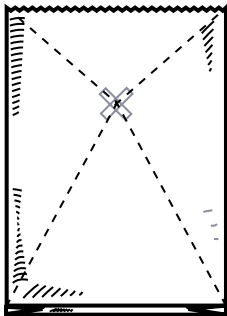

a.

Cut off bottom of bag so that both ends are open. On one wide side of the bag, mark a point in the center, one third of the way down from the top edge. Then draw diagonal lines from the corners of the bag to this center point (see figure a.) Cut along the lines to make wings. Discard the 2 loose pieces.

Turn the bag over with the remaining wide side facing you. Fold the two narrow sides in half back toward the wide side (using the folds already in the narrow sides) and tape the long edges of the wings to the remaining wide side of the bag (see figure b.) Cut a vent and put a piece of tape across each corner for reinforcement (see figure b.)

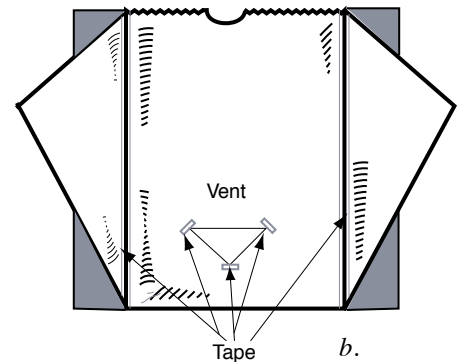

Draw a design on both sides of the bag. Punch holes in the “wings” about 1/4” in from the points. Cut a 6” length of string. Tie one end into each hole (see figure c.) You can attach more string to the center of the 6” string for flying or use the short length to swing the kite.

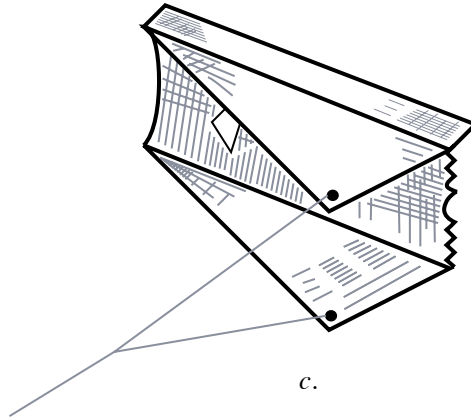

2 KINGS — LESSON 1

Before you begin your lesson:

- a. Pray for God's Holy Spirit to help you answer the questions.
- b. Some questions may be too hard; it's ok to write "I don't know."
- c. Think about what God's Word is telling you for today.
- d. With some questions, it might be helpful to write the scripture verse on your paper.

Read 2 Kings chapter 1, verses 1 - 8.

1. In 1 Kings 22:51-53, we learned that Ahaziah, Ahab's son, became king over Israel and he reigned for two years. But he was not a good king. He led Israel in worshiping idols which is sin. One day Ahaziah fell. There is no information why he fell or what he hurt. But he wasn't getting better. To whom did he send his messengers to find out if he was ever going to get better?
 2. What was Ahaziah's answer and who gave it?
3. People today want to know what is going to happen in the future. They go to palm readers, they read horoscopes, some even play games that seem to predict the future. God says this is sin. It is very wrong. What does Acts 1:7 say about looking into the future?

Read 2 Kings chapter 1, verses 9 - 12.

1. What did the first captain say to Elijah?
2. What did the second captain add in what he said to Elijah?

3. How many men were killed by fire?

Read 2 Kings chapter 1, verses 13 - 18.

1. Ahaziah sent another captain and his fifty men. This captain did something different than the first two. What did he do?

2. **HARD:** What do you learn about a judge in the parable Jesus told in Luke 18:2? (If you have The New American Standard Bible, use it for this answer.)

3. What does Psalm 14:1 say about a fool?

4. What do these verses tell us is the way we should live?

1 Thessalonians 4:11,12

1 Peter 2:17

5. What does Psalm 111:10 say about wisdom?

6. **PERSONAL:** Which captain are you more like, the foolish one or the wise one?

Read 2 Kings chapter 2, verses 1 - 12.

1. **HARD:** God must have told Elijah what was going to happen to him. What was it?

2. What did the company or sons of prophets say to Elisha when he was in Bethel, verse 3, and at Jericho, verse 5?

3. What did Elisha want from Elijah?

4. What happened to Elijah?

Read 2 Kings, chapter 2, verses 13 - 22.

1. Even though the prophets saw what happened and said Elijah's spirit was on Elisha, they still were not sure of what they saw. So they asked Elisha if they could search for Elijah, or his body, to prepare it for burial. How long were they gone?

2. How did Elisha fix the bad water in Jericho?

3. The young men Elisha met on his way to Bethel were making fun of him. The words they used were slang for that day. They thought he too should go where Elijah went. They were not showing respect to Elisha, nor the God Elisha served. What does Leviticus 19:32 say about showing people respect? Remember elderly, or older, is anyone who is several years older than you.

2 KINGS LESSON 1 ANSWERS

Read 2 Kings chapter 1, verses 1 - 8.

1. In 1 Kings 22:51-53, we learned that Ahaziah, Ahab's son, became king over Israel and he reigned for two years. But he was not a good king. He led Israel in worshiping idols which is sin. One day Ahaziah fell. There is no information why he fell or what he hurt. But he wasn't getting better. To whom did he send his messengers to find out if he was ever going to get better? Verse 2: "Ahaziah was Israel's new king. He fell off the upstairs porch of his palace at Samaria. And he was badly hurt. So he sent messengers to the temple god Baal-zebub at Ekron. He sent them to ask if he would get better." [Ahaziah turned to a false god. Ekron is a city in the land of Philistia, where the god that told about the future was housed. Baal-zebub is two Hebrew words: Baal means lord or god; zebub in the verb sense means to dangle, to move quickly; in the noun sense means to fly, or is a reference to the insect fly. So Baal-zebub is the lord of the fly. There is no reference to its shape or exactly what it did. One of its functions was to speak through its seers and witches about the future, and that is why Ahaziah sought this god out. After Ahab died Moab had rebelled against Israel's control. The king of Moab was Mesha, who may have felt Ahaziah was not as strong a ruler as Ahab and that rebellion would work.]
2. What was Ahaziah's answer and who gave it? Verse 4: "Therefore this is what the Lord says: 'You will not leave the bed you are lying on. **You will certainly die!**' So Elijah went" (NIV).
3. People today want to know what is going to happen in the future. They go to palm readers, they read horoscopes, some even play games that seem to predict the future. God says this is sin. It is very wrong. What does Acts 1:7 say about looking into the future? "He said to them: 'It is not for you to know the times or dates the Father has set by his own authority.'"

Read 2 Kings chapter 1, verses 9 - 12.

1. What did the first captain say to Elijah? Verse 9: "Then he sent to Elijah a captain with his company of fifty men. The captain went up to Elijah, who was sitting on the top of a hill, and said to him, 'Man of God, the kings says, "**Come down!**"'"
2. What did the second captain add in what he said to Elijah? Verse 11: "At this the king sent to Elijah another captain with his fifty men. The captain said to him, 'Man of God, this is what the king says, "**Come down at once!**"'" (NIV) [quickly].
3. How many men were killed by fire? 102: 50 and captain in verse 10; 50 and captain in verse 12. [This contingency was sent to arrest Elijah. The words spoken were those of contempt for God and His prophet, especially since Elijah's reputation was well known throughout the land.]

Read 2 Kings chapter 1, verses 13 - 18.

1. Ahaziah sent another captain and his fifty men. This captain did something different than the first two. What did he do? Verses 13,14: “Once more the king sent 50 men. But this time the captain **fell to his knees** before Elijah. He **pleaded with him**, ‘O man of God! Please save my life. And please, save the lives of these your 50 servants. Have mercy on us! Don’t destroy us as you did the others.’” [This captain showed humility and recognized that Elijah was truly a man of God.]
2. **HARD:** What do you learn about a judge in the parable Jesus told in Luke 18:2? (If you have The New American Standard Bible, use it for this answer.) “Saying, ‘there was in a certain city **a judge who did not fear God, and did not respect man**’” (NAS).
3. What does Psalm 14:1 say about a fool? “That man is a fool who says, ‘There is no God!’ Anyone who talks like that is evil. He cannot really be a good person at all.”
4. What do these verses tell us is the way we should live?

1 Thessalonians 4:11,12 “Your ambition should be to live a quiet life. Mind your own business and do your own work, as we told you before. Then people who aren’t Christians will trust and respect you. You won’t need to depend on others for the money to pay your bills.”

1 Peter 2:17 “Show respect for everyone. Love Christians everywhere. Fear God and honor the government.”
5. What does Psalm 111:10 say about wisdom? “How can men be wise? The only way to begin is by respecting God. For growth in wisdom comes from obeying his laws. Praise his name forever.”
6. **PERSONAL:** Which captain are you more like, the foolish one or the wise one?

Read 2 Kings chapter 2, verses 1 - 12.

1. **HARD:** God must have told Elijah what was going to happen to him. What was it? Verse 1: “Now the time came for the Lord to take Elijah to heaven. The Lord was going to take him to heaven by means of a whirlwind!” [It is at the Jordan River where the Lord will take Elijah. But first Elijah visits the places where the schools for prophets had been established, maybe to give one last teaching. Nothing is recorded as to why he didn’t go directly to the Jordan, but made stops along the way first.]
2. What did the company or sons of prophets say to Elisha when he was in Bethel, verse 3, and at Jericho, verse 5? Verse 3: “The school of young prophets at Bethel came out to meet them. They asked Elisha, ‘Did you know that the Lord is going to take Elijah away from you today?’” [Elisha knew what was going to happen and he asked for their silence because he didn’t want to be reminded of the sorrow he would soon experience.]

3. What did Elisha want from Elijah? Verse 9b: “Elisha said, ‘Please give me **double the prophetic power you have had.**’” [This is reference to the first-born son’s material inheritance, although Elisha was requesting a spiritual blessing. Elisha wanted to be the leader of the prophets, to be the first among them. Elisha wanted to carry on Elijah’s ministry under God. Elisha wanted divine strength to carry out his new role as spiritual leader. But this privilege was not one Elijah could give. That is why he stated “If you see me when I am taken from you, then you will get what you asked. But if not, you won’t.”]
4. What happened to Elijah? Verse 11: “They were walking along, talking. Then suddenly a chariot of fire came. It was pulled by horses of fire. It drove between them and separated them. Then Elijah was carried by a whirlwind into heaven.”

Read 2 Kings, chapter 2, verses 13 - 22.

1. Even though the prophets saw what happened and said Elijah’s spirit was on Elisha, they still were not sure of what they saw. So they asked Elisha if they could search for Elijah, or his body, to prepare it for burial. How long were they gone? Verse 17b: “Then 50 men looked for Elijah for **three days.** But they didn’t find him.”
2. How did Elisha fix the bad water in Jericho? Verses 20,21: ‘Well,’ he said, ‘bring me a new bowl filled with salt.’ So they brought it to him. Then he went out to the city well and **threw the salt in.** He said, **‘The Lord has healed these waters. They shall no longer cause death or keep the land from growing crops.’**” [Elisha is using symbolism. The new bowl represents himself, the new prophet, God’s new instrument. Salt purifies and preserves. It was used in the Israelites’ daily grain offerings. Salt normally does not make water taste better. Here, however, Elisha was demonstrating that it is the Lord who heals barrenness, not Baal, the pagan god of fertility.]
3. The young men Elisha met on his way to Bethel were making fun of him. The words they used were slang for that day. They thought he too should go where Elijah went. They were not showing respect to Elisha, nor to the God Elisha served. What does Leviticus 19:32 say about showing people respect? Remember elderly, or older, is anyone who is several years older than you. “You shall give due honor and respect to the elderly. You shall do this in the fear of God. **I am the Lord.**”